



# saet

# CEMTEC

Cement and Mining Technology GmbH

AN 16-55-G520

Application-note

## WET LIMESTONE MILLING SYSTEM FOR DeSOX TREATMENT OF PLANT EXHAUST GAS - TORREVALDALIGA NORD POWER PLANT

Gypsum-Limestone Process is the most diffused method used to eliminate Sulphur Oxides ( $SO_x$ ) present in Combustion Exhaust Gases of Thermoelectric Plants. Combustion Exhaust Gases, after an accurate washing, are sprinkled with a suspension of water and limestone and then driven through an Absorber (ABS); the  $SO_2$  is transferred from the combustion gases to the liquid suspension by the direct contact of these two elements.

Torrevaldaliga Nord Power Plant is located in the municipality of Civitavecchia at about 45 km from Rome.

The plant has been realized by SAET in partnership with CEMTEC, an Austrian company leader in the milling system plants

The scope of supply was basic and detailed engineering, "Turn key" mechanical and electrical realization, SCADA supervisor system.

The limestone will be discharged from the Stacker Belt Conveyor to the Storage Silos, each one of 250m<sup>3</sup> net capacity. A Vibrating Extractor will be installed, complete of limestone chute and isolation gate, at Silos outlet to allow material flushing to the downstream Belt Weight Feeder.

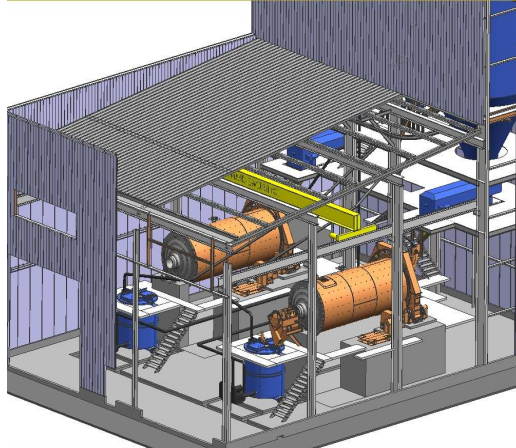

Limestone Wet System - lay-out



SAET Weight Belt feeders DPN 10



Limestone Milling system - General view of the plant during construction

The Belt Weight Feeder will meter an accurate flow rate of limestone to the Ball Mill; in this way a controlled flow rate of material will be fed to the Ball Mill in order to guarantee the required flow rate, solids concentration and solids size at Mill outlet.

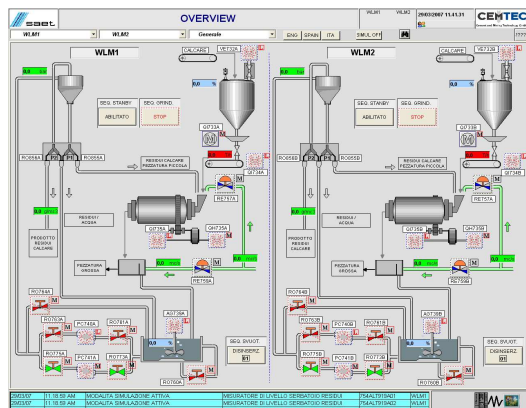

SCADA view of the Limestone Milling System



vibrating extractors

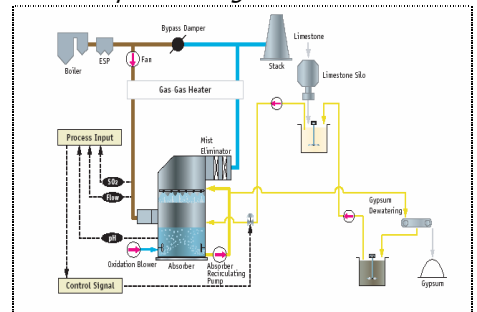

General functioning scheme of Desox Plant

**saet** Padova  
SISTEMI ED IMPIANTI  
ENERGIA E AMBIENTE INDUSTRIA DI PROCESSO AUTOMAZIONE LOGISTICA

SAET S.p.A. - Via Moravia, 8  
35030 Selvazzano D. (PD)  
Tel +39(0)498989711  
Fax +39(0)498975299

E-mail: info@saetpd.it - Internet: www.saetpd.it